

# Nano - N

5 l.

EN



SAFETY INFORMATION  
O&M INFORMATION  
INSTALLATION MANUAL  
TDS - TECHNICAL DATA SHEET

**Manufactured by OSO Hotwater AS**  
Industriveien 1 - 3300 Hokksund - Norway  
Tel: + 47 32 25 00 00 / Fax: + 47 32 25 00 90  
E-mail: [oso@oso.no](mailto:oso@oso.no) / [www.osohotwater.com](http://www.osohotwater.com)

146007-09 - 10-2021

# OSO

HOT WATER

# CONTENTS

<b>1. Safety instructions</b> .....	3
1.1 General information.....	3
1.2 Safety instructions for users.....	4
1.3 Safety instructions for installers.....	4
<b>2. Product description</b> .....	5
2.1. Product identification.....	5
2.2. Intended use .....	5
2.3 CE marking.....	5
2.4 Technical data.....	5
2.5. ErP data (TDS).....	5
<b>3. Installation instructions</b> .....	6
3.1. Products covered by these instructions.....	6
3.2. Included in delivery.....	6
3.3. Product dimensions.....	6
3.4. Requirements for installation location .....	7
3.5. Pipe installation.....	8
3.6. Electrical installation.....	10
<b>4. Initial commissioning</b> .....	12
4.1. Filling with water .....	12
4.2. Turning on the power .....	12
4.3. Control points.....	12
4.4. Emptying of water.....	12
4.5. Handover to end-user.....	12
<b>5. User Guide</b> .....	13
5.1. Settings.....	13
5.2. Maintenance.....	13
<b>6. Troubleshooting</b> .....	14
6.1. Faults and fixes.....	14
<b>7. Warranty conditions</b> .....	15
7.1. Warranty and registration.....	15
7.2. Customer service.....	15
<b>8. Removing the product</b> .....	15
8.1. Removal.....	15
8.2. Returns scheme .....	15



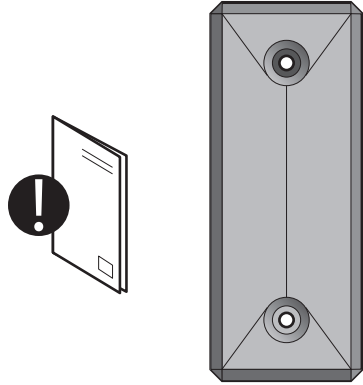

# 1. SAFETY INSTRUCTIONS

## 1.1 General information









- Read the following safety instructions carefully before installing, maintaining or adjusting the water heater.
- Personal injury or material damage may result if the product is not installed or used in the intended manner.
- Keep this manual and other relevant documents where they are accessible for future reference.
- The manufacturer assumes compliance (by the end-user) with the safety, operating and maintenance instructions supplied and (by the installer) with the fitting manual and relevant standards and regulations in effect at the date of installation.





Symbols used in this manual:









 WARNING	Could cause serious injury or death
 CAUTION	Could cause minor or moderate injury or damage to property
 DO NOT	
 DO	





## 1.2 Safety instructions for users

 WARNING	
	The overflow from the safety valve must NOT be sealed or plugged.
	The product must NOT be covered over the cover on the front.
	The product must NOT be modified or changed from its original state.
	Fitting an external control unit managing the power supply to the product is NOT allowed without approval from the manufacturer.
	Children must NOT play with the product or go near it without supervision.
	The product shall be filled with water before the power is switched on.
	Maintenance/settings shall only be carried out by persons over 18 years of age, with sufficient understanding

 CAUTION	
	The product must not be exposed to frost, over-pressure, over-voltage or chlorine treatment. See warranty provisions.
	Maintenance/settings shall not be carried out by persons of diminished physical or mental capacity, unless they have been instructed in the correct use by someone responsible for their safety.

## 1.3 Safety instructions for installers

 WARNING	
	The overflow from the safety valve must NOT be sealed or plugged.
	Fitting an external control unit managing the power supply to the product is NOT allowed without approval from the manufacturer.
	Any overflow pipe from the safety valve MUST be >1/2 mm inside, clear, undamaged and frost-free with a fall to the drain.
	Fixed electric fittings shall be used for installation in new homes or when changing an existing electrical setup in accordance with regulations.
	The mains cable shall withstand 90°C. A strain reliever must be fitted.
	The product shall be filled with water before the power is switched on.
	The relevant regulations and standards, and this installation manual, must be followed.

 CAUTION	
	The product shall be fitted in accordance with Part G3 of building regulations. Liability for consequential damage will only apply if this is followed.
	The product shall be properly aligned vertically and horizontally, on a floor or wall suitable for the total weight of the product when in operation. See type plate.
	The product shall be mounted to allow access to the junction box when needed.

## 2. PRODUCT DESCRIPTION

### 2.1 Product identification

Identification details for your product can be found on the type plate fixed to the product. The type plate contains details of the product in accordance with EN 12897:2016 and EN 60335-2-21, as well as other useful data. See Declaration of Conformity at [www.osohotwater.co.uk](http://www.osohotwater.co.uk) for more information.

OSO products are designed and manufactured in accordance with:

- Pressure vessel standard EN 12897:2016
- Safety standard EN 60335-2-21
- Welding standard EN ISO 3834-2

OSO Hotwater AS is certified for

- Quality ISO 9001
- Environment ISO 14001
- Work environment ISO 45001

### 2.2 Intended use

The Nano is designed to supply homes with hot water, and to reheat water where there are long lengths of pipe etc.

The product is designed to be mounted on a wall

### 2.3 UKCA marking



The UKCA mark shows that the product complies with the relevant Directives. See Declaration of Conformity at [www.osohotwater.co.uk](http://www.osohotwater.co.uk) for more information.

The product complies with Directives for:

- Low voltage LVD 2014/35/EU
- Electromagnetic compatibility EMC 2014/30/EU
- Pressurised Equipment Directive PED 2014/68/EU

Any safety valve(s) used should be CE-marked and comply with the PED 2014/68/EU.

### 2.4 Technical data

NRF no.	Product code:	Capacity persons	Weight kg.	WxDxH mm.	Freight vol. m <sup>3</sup>	IP class	Heating time hours $\Delta t$ 65°C	Heat loss W
1080 6051	N 5 - 2.8 kW 1x230V	0.5	12	200x234x500	0.03	IP44	0.1	13

### 2.5 ErP data - Technical Data Sheet

Brand	Model-no.	Model name	Tap profile	ErP Rating	Energy eff. %	AEC - kWh/a	Thermostat setting °C	Volume 40°C water
OSO Hotwater AS	1080 6051	Nano - N 5 - 2.8 kW 1x230V	XXS	A	35	525	60	7
Directive: 2010/30/EU Regulation: EU 812/2013			Directive: 2009/125/EC Regulation: EU 814/2013					
Efficiency-tested according to standard: EN 50440: 2015								

## 3. INSTALLATION INSTRUCTIONS

### 3.1 Products covered by these instructions

800 0051 Nano - N 5

### 3.2 Included in delivery

Ref no.	Number of	Description
1	1	Thermostat
2	1	Heating element
3	1	Installation manual (this document)
4	1	Mounting band with 2 screws + washers
5	1	Water heater
6	1	Safety valve (supplied loose)

### 3.3 Product dimensions

All dimensions in mm.

Product.	A	B	C			
N 5	200	234	500			

Tolerance +/- 5 mm.

#### 3.3.1 Delivery

The product shall be transported carefully, with packaging.

#### 3.3.2 Removing the insulation

The product is fitted with a four-port insulation cap with quick-fit locks that can easily be pulled apart and put together without the use of tools. Care should be taken when fitting/dismantling to ensure that the locking mechanisms and insulation are not damaged.

Removing the insulation cap:

1. Pull one of the wedge-shaped end pieces out by gripping it with your fingers in the recess by the pipe joint; see illustration. (K).
2. Repeat with the end piece at the opposite end.
3. Pull off the front piece by gripping the edges and pulling straight out. Inner tank and junction box with screw holes for wall fitting are now accessible.

Fitting the insulation cap:

1. Press the front piece into the fasteners.
2. Press the two end pieces into place. Ensure that the locking mechanisms slide into each other correctly and that the coloured rings (red/blue) indicating HW and CW are positioned correctly in the slots.

**IMPORTANT:** If the insulation is not correctly and

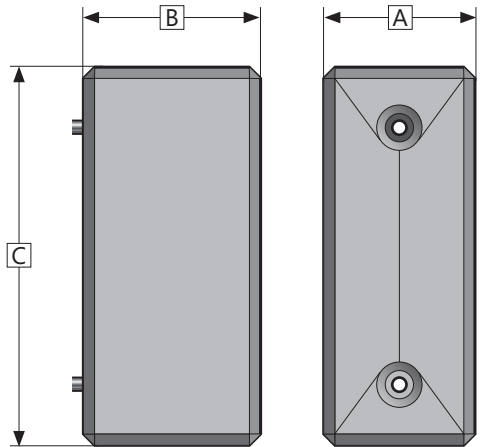
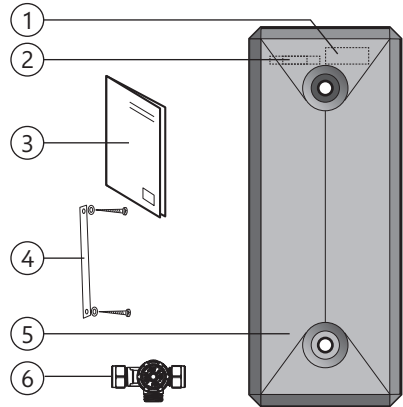

#### ⚠ WARNING

Before any work is done, the power supply must be disconnected and secured against activation while the work is in progress.

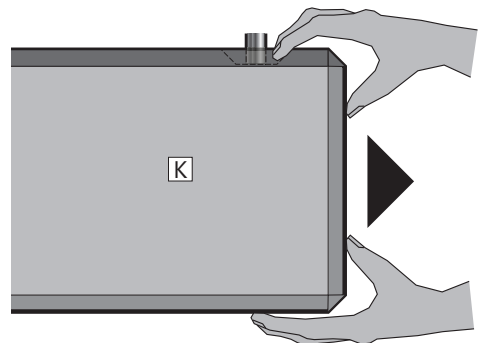

completely fitted, the product will not achieve the specified ErP energy rating. The energy consumption of the product could increase.

### 3.3.3 Wall fitting

The product is designed to be mounted on a wall. When the insulation cap is removed, there is easy access to the screw holes (D).

The Nano is attached to the wall with the supplied fastening metal band (V); see illustration. The metal band is bent/placed around the middle of the tank and fixed to the wall through the holes in the insulation, using the screws/washers supplied. Ensure that the connectors do not press on the insulation parts. Use a torx type bit (T25). Tighten the screws until the insulation around the screw holes deforms slightly.

### 3.3.4 Reversing the inner tank

For horizontal mounting, the inner tank can be reversed if it is desirable to swap the CW and HW connections for ease of fitting. Important: This can only be done when the electricity is not connected.

1. Remove the insulation (see 3.3.2).
2. Remove the electrical cover by loosening the nut (E). Then unscrew the strain reliever for the mains cable (F) and remove the electrical cover.
3. The electrical cover (I) may be modified by opening the alternative fixing for the strain reliever (K). Material in the recess should be removed and the strain reliever with cable

fitted into the new channel.

4. Remove the fastening band (V). Pull the tank out so the connections clear the attachment points (H). Turn the tank 180° and push it back into the attachment points. Refit the fastening band.
5. Ensure that connections and the coloured rings (red/blue) indicating HW and CW are positioned correctly in the slots.
6. Fit the electrical cover with the nut (E), then fit the insulation cap. The end-parts of the insulation must now swap places.
7. The product has built-in channels in the back (J) for simple and tidy routing of the mains cable at the back of the product.

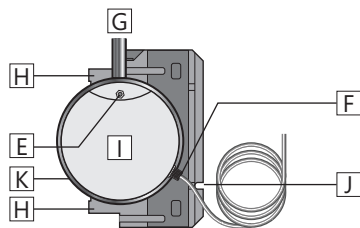
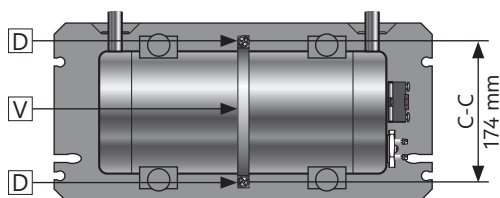

## 3.4 Requirements for installation location and positioning

⚠ CAUTION	
❗	The product shall be fitted in accordance with Part G3 of building regulations. Liability for consequential damage will only apply if this is followed.
❗	The safety valve supplied must be mounted on the cold water supply to the boiler. See section 3.5.2.
❗	The product shall be placed in a dry and permanently frost-free position.
❗	The product shall be mounted on a wall suitable for the total weight of the product in operation.
❗	<b>If the product is fitted horizontally, the pipe connectors must point straight up.</b> It is recommended that the product be screwed tight to the wall or a suitable surface regardless of the method chosen; use the screw holes (D). <b>If the product is fitted vertically, the electric box must face upwards. See page 8.</b>
❗	The product shall be mounted to allow access to the junction box when needed. Mains cable can be placed in the channels in the back of the product. Mains cable for wall socket should be laid where it is not exposed to any mechanical or chemical influence.
❗	The product shall be easily accessible in the home for servicing and maintenance.

### 3.5 Pipe installation

The product is designed to be permanently connected to the mains water supply. Approved pipes of the correct size should be used for installation. The relevant standards and regulations must be followed.

Product.	CW (1)	HW (2)	Overflow (4)
N 5	ø15 mm	ø15 mm	1/2" outside thread

#### 3.5.1 Incoming water pressure

The efficiency of the product depends on the incoming cold water pressure. The water pressure should be min. 2 bar and max. 6 bar throughout the day. Excessive water pressure can be adjusted by installing a pressure reduction valve.

#### 3.5.2 Fitting cold and hot water pipes (CW-HW), safety valve and overflow pipe

A) Place product in the desired position. If the product is fitted horizontally, the pipe connectors must point straight up. It is recommended that the product is secured to a wall or a suitable surface regardless of the method chosen; use the screw holes D, see page 7.

If the product is fitted vertically, the electric box MUST face upwards. See pt. 3.5.7.

B) CW (1)/HW (2) fit pipes of suitable size to the connections, tighten according to table 3.5.3.

- For larger pipe sizes, a reducer can be used.

C) The safety valve supplied (3) must be fitted to the incoming CW supply pipe.

D) Any overflow pipe (5)  $\geq 1/2"$  inside should be run to the overflow on the safety valve (4);

- Connect to 1/2" outside thread. Ring clamp connector may be used (not included)
- Clear, undamaged and frost-free with a fall to the drain.

#### 3.5.3 Torque settings

Component	Torque
Connection to CW/HW (ø15)	40 Nm (+/- 3)
Ring clamp connection to safety valve	40 Nm (+/- 3)
Screws for mounting band	Depending on surface*

\* Fastening band for wall mounting fitted as described in section 3.3.3. Screws for wall mounting tightened until the insulation material starts to deform slightly.

The product must be fitted to a wall surface designed to withstand the weight of the product in operation.

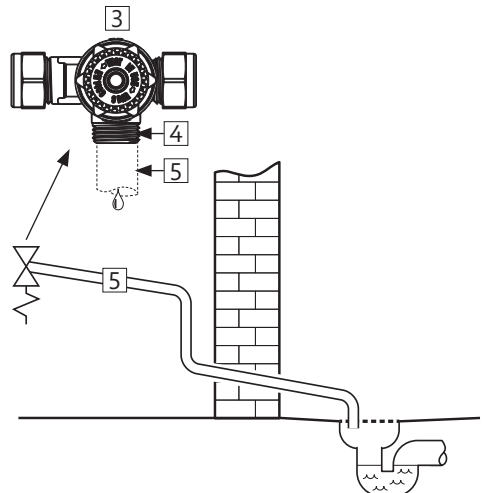
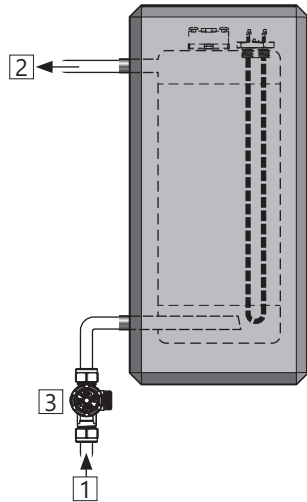
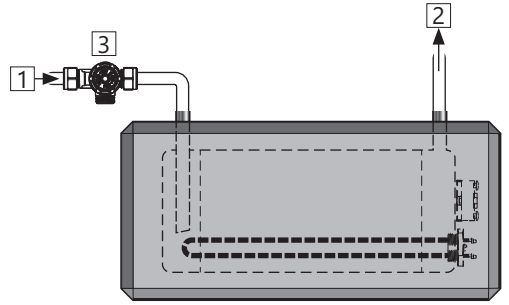



### 3.5.5 Installation instructions

#### ⚠ WARNING

❗	The product shall be filled with water before the power is switched on.
❗	Any overflow pipe from the safety valve MUST be $>1/2$ mm inside, clear, undamaged and frost-free with a fall to the drain.

#### ⚠ CAUTION

❗	Fixed electric fittings shall be used for installation in new homes or when changing an existing electrical setup in accordance with regulations.
❗	The product shall be properly aligned vertically and horizontally, on a wall or floor suitable for the total weight of the product when in operation. See type plate.
❗	<b>If the product is fitted horizontally, the pipe connectors must point straight up.</b> It is recommended that the product is fastened to a wall or suitable surface regardless of the method chosen; use the screw holes D, see page 7. <b>If the product is fitted vertically, the electric box must face upwards. See illustration below.</b>
❗	The product shall be mounted in a way that allows access to the junction box when needed.

### 3.5.6 Installation recommendation

#### RECOMMENDATION

❗	The safety valve supplied must be fitted to the incoming cold water supply pipe. See section 3.5.2.
-	If a non-return valve is fitted a reduction valve and expansion vessel shall be fitted to avoid dripping from the safety valve overflow.
-	If the maximum water pressure exceeds 6 bar in a 24-hour period, a reduction valve and expansion vessel shall be fitted.

### 3.5.7 Installation positions

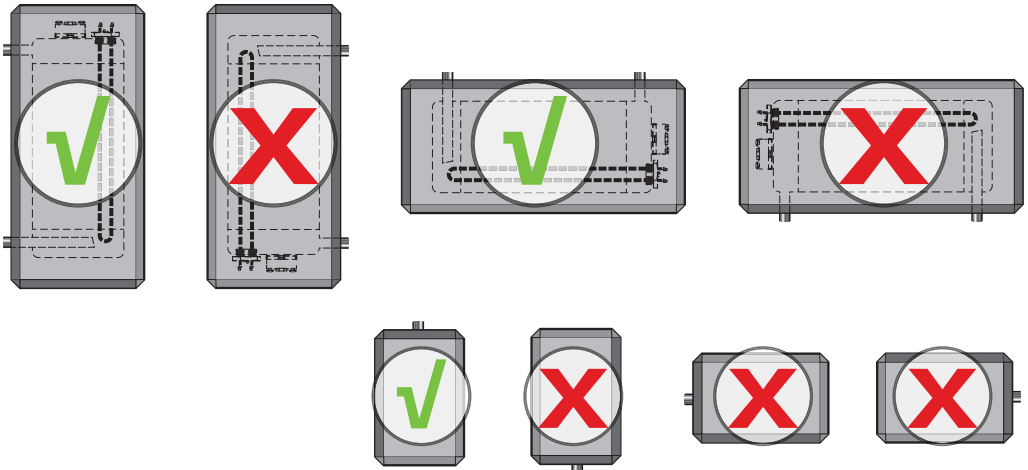

### 3.6 Electrical installation

Fixed electric fittings shall be used for installation in new homes or when changing an existing electrical setup in accordance with regulations. A mains cable with plug for wall socket can be used when replacing the product without changing the electrical setup. Any fixed electric fittings must be installed by an authorised electrician.

Fitting or retrofitting an external power supply control unit to the product or its power supply must only be performed by an authorized electrician. The control unit must be approved by the product manufacturer.

The relevant standards and regulations must be followed.

#### 3.6.1 Electrical components

Component	Note
Safety thermostat	85°C thermal cut-out
Work thermostat	40-70°C adjustable
Heating element	1-phase 230 V
Mains cable with plug	Heat-resistant
Internal wires	Heat-resistant

#### 3.6.2 Electrical connections in the junction box

⚠ WARNING
Constant voltage present at terminals R and S. Before any electrical work is done, the power supply must be disconnected and secured against activation while the work is in progress.

- A) Blue wire (L) – Neutral – connected to point '1' on the safety thermostat.
- B) Brown wire (N) – Live – connected to point '3' on the safety thermostat.
- C) Yellow wire with green stripe  $\oplus$  – Earth – connected to the earth terminal on the attachment for the thermostat.
- D) Internal wires from the element to the thermostat are connected to point '4' on the safety thermostat and point '2' on the work thermostat. See illustration.

#### 3.6.3 Changing the capacity

The capacity of the element can be halved to 1.5 kW by removing the jumpers (5) connecting the two heating pipes on the element. The product can then be connected to a 10A fuse. Must be performed by an authorized electrician.

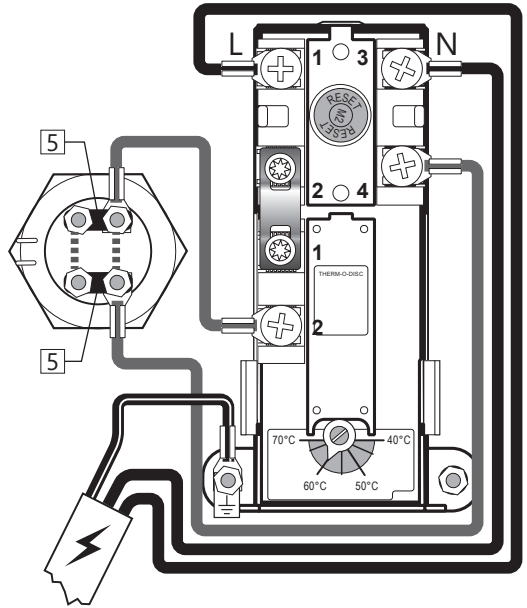







Electrical connection, diagram

#### 3.6.4 Torque settings

Component	Torque
1" heating element	60 Nm (+/- 5)
Thermostat screws	2 Nm (+/- 0.1)
Screw on the element head	2 Nm (+/- 0.1)

### 3.6.5 Installation instructions

 WARNING	
	Fitting an external control unit managing the power supply to the product is NOT allowed without approval from the manufacturer.
	The product shall be filled with water before the power is switched on.
	Fixed electric fittings shall be used for installation in new homes or when changing an existing electrical setup in accordance with regulations.
	The mains cable shall withstand 90°C. A strain reliever must be fitted.

 CAUTION	
	The product must have a clearance for servicing of 40 cm in front and side.

### 3.6.6 Fitting recommendation

RECOMMENDATION	
-	The mains cable supplied shall be used with fixed electric fittings.
-	Mains cable for wall socket shall be laid where it is not exposed to harmful contact.
-	For products with $\leq 3\text{kW}$ capacity, The unit must be permanently connected to a 20amp DP Switch ( BS3455) with minimum 3mm separation and 2.5mm Flexible Cable HR to 85c (HOFR to BS 6141 Table 8), installation shall comply with current IEE Regulations. Immersion Heater rating is 230V x 3kW. All internal wiring is factory fitted.

## 4. INITIAL COMMISSIONING

### 4.1 Filling with water

First check that all pipes are connected correctly. Then proceed as follows:

- A) Open a hot tap – leave it open
- B) Open the cold water supply to the product.

Check that the water from the open hot water tap is flowing freely, without any bubbles or air locks.

- A) Close hot tap.

### 4.2 Turning on the power

When the cylinder has been filled with water, the power can be switched on.

- A) Insert plug into specified wall socket or turn on switch/breaker.

### 4.3 Control points

- A) Check that all pipe connections to/from the product are tight and not leaking.
- B) Check that the power supply to the product is not at risk of exposure to mechanical, thermal or chemical damage, and is not connected to a non approved power supply control unit.
- C) Check that any overflow pipe from the safety valve is uninterrupted, undamaged and frost-free with a fall to the drain.
- D) Check that the product is standing firmly vertically and horizontally.

### 4.4 Emptying of water

**⚠ WARNING**

The water temperature in the product may exceed 75°C and could cause scalding. Before emptying, a hot tap should be opened to the max. pressure/temperature for min. 3 minutes.

- A) Disconnect the power supply.
- B) Shut off incoming cold water supply.
- C) Disconnect the pipe connections to the cold and hot water feeds on the product.
- D) Remove the insulation cap and loosen the wall mounting band.
- E) Bring the heater to a drain, sink or other suitable place and empty the tank by turning the pipe connections upside down. Keep in mind- that both the water and the product may be very hot.

When the heater is to be put into operation again, it must be filled with water and the tank

vented by opening a hot water tap to the maximum pressure until the water flows in an even stream. The power supply must not be switched on until this is done. Check that the pipe connections for CW and HW are still tight and not leaking after 3-4 hours of operation.

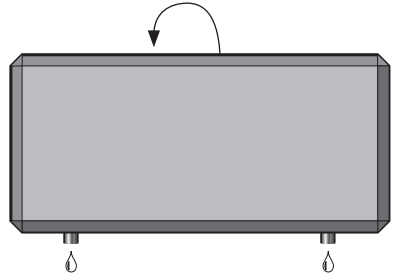

### 4.5 Handover to end-user

**THE INSTALLER MUST:**

- |  |
|--|
| Brief the end-user on safety and maintenance instructions. |
| Brief the end-user on settings and emptying the product.   |
| Hand this installation manual over to the end-user.        |
| Enter contact details on the type plate on the product.    |

## 5. USER GUIDE

### 5.1 Settings

#### 5.1.1 Thermostat setting

The thermostat on the product is adjustable from 40-70°C. The thermostat should not be set lower than 60°C to prevent bacteria growth. To adjust the temperature:

- A) Disconnect the power supply.
- B) Dismantle the electrical cover on the heater by removing the insulation cap (see section 3.3.4) and then unscrew the cover with a suitable tool.
- C) Adjust the temperature on the thermostat (7) with a screwdriver.

Fit electrical cover and insulation before the power supply is connected.

#### ⚠ WARNING

Changing the temperature setting on the thermostat will change the temperature of the water at the tap, and may carry a risk of scalding. Where necessary, a mixer valve should be fitted (not included).

#### 5.1.2 Resetting the safety thermostat

The safety thermostat on the product cuts out when there is a risk of overheating. This is reset by removing the cover (see 5.1 A and B) and pressing the red 'RESET' button (6). If the thermostat cuts out repeatedly, contact the installer.

#### ⚠ WARNING

Constant voltage present in the junction box. Before any electrical work is done, the power supply must be disconnected and secured against activation while the work is in progress.

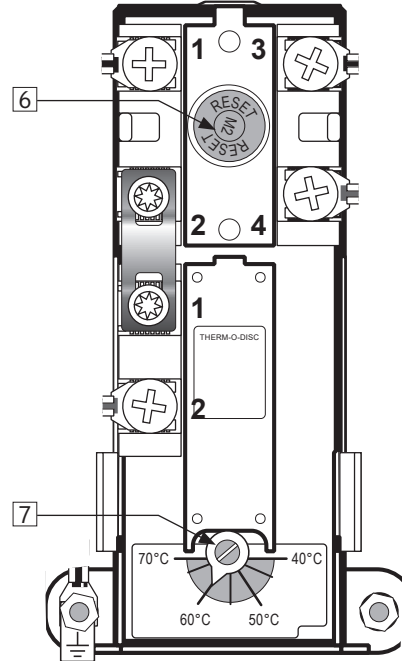

### 5.2 Maintenance

#### MAINTENANCE INSTRUCTIONS

- |   |  |
|---|--|
| ❗ | Maintenance shall be carried out by persons over 18 years of age, with sufficient understanding. |
| ❗ | Annual inspection of safety valve:   |
| - | Open valve for 1 min. by turning the knob (2) approx. 90 degrees to the open position.           |
| - | Visually check that the water is flowing freely to the drain.                                    |
| - | YES = OK. Close the valve by turning the knob (2) a further 90 degrees to the closed position.   |
| - | NO = NOT OK. Disconnect power supply / shut off water supply. Contact installer.                 |

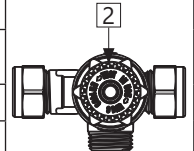

## 6. TROUBLESHOOTING

### 6.1 Faults and fixes

If problems arise when the product is in use, check for possible faults and fixes in the table. If the problem is not shown in the troubleshoot-

ing table or you are unsure what is wrong, contact the installer (see type plate on the product) or OSO Hotwater AS - see section 7.1.

TROUBLESHOOTING		
Problem	Possible cause of fault	Possible solution
<b>There is leakage/dripping from the safety valve/ there is often water on the floor by the cylinder in the morning</b>	Pressure reduction valve, water meter or blocked non-return valve on the water intake.	Fit AX expansion vessel with absorbs expansion during heating, and fit pressure reduction valve for stable water pressure inside the home. The pressure reduction valve is adjusted in according to the pressure in the expansion vessel. Contact auth. installer.
	Water pressure into the home is too high.	
	The safety valve is worn or there are particles stuck between the membrane and the valve seat because the water is dirty	Flush with water through the safety valve. Open valve for approx. 1 minute. See section 5.2. If the valve still leaks, it must be replaced. Contact auth. installer.
<b>No hot water</b>	Leak from heating element.	Verify as follows: a) cut the electric supply, b) unscrew the cover, c) visually check whether there is a leak from the heating element. If so, replace the gasket/heating element. Contact auth. installer.
	Power supply interrupted.	Verify that the fuse is on / the plug is plugged in to the wall contact / the earth breaker has not tripped.
	Thermostat has cut out.	Press the 'RESET' button on the safety thermostat; see 'User guide'.
	Heating element is defective.	Replace heating element. Contact auth. installer.
<b>Not enough hot water</b>	Leak in hot water pipe	Check the hot water pipes and taps in the house for leaks. If a leak is detected: Contact auth. installer.
	High consumption in the home.	Raise the temperature on the thermostat to the maximum; see 'User guide'. Switch to a larger OSO water heater. Contact auth. installer.
<b>Not high enough temperature</b>	The thermostat is set for low temperatures.	Raise the temperature on the thermostat to the maximum; see 'User guide'.
	Change from cold to hot water in taps.	Contact auth. installer.
<b>Fuse/earth breaker trips repeatedly</b>	Possible fault in the heater's electrical system.	Verify as follows: a) cut the electric supply, b) unscrew the cover, c) visually check the junction box for any problems. If so, contact auth. installer to check. Fit the cover.
<b>Knocking in the pipes when the hot tap is closed</b>	Large pressure increase when the tap is closed quickly.	Completely normal. Fit AX expansion vessel if troublesome. Contact auth. installer.

## 7. WARRANTY CONDITIONS - applies to UK only

### 1. Scope

OSO Hotwater UK Ltd. (hereinafter called OSO) warrants for 2 years from the date of purchase, that the Product will: i) conform to OSO specification, ii) be free from defects in materials and workmanship, subject to conditions below. All components carry a 2-year warranty. The warranty is voluntarily extended by OSO to 25 years for the stainless steel inner tank. This extended warranty only applies to Products purchased by a consumer, that has been installed for private use and that has been distributed by OSO or by a distributor where the Products have been originally sold by OSO.

The extended warranty does not apply to Products purchased by commercial entities or for Products that have been installed for commercial use. These shall be subject only to the mandatory provisions of the law. The conditions and limitations set out below shall apply.

### 2. Coverage

If a defect arises and a valid claim is received within the statutory warranty period, at its option and to the extent permitted by law, OSO shall either; i) repair the defect, or; ii) replace the product with a product that is identical or similar in function, or; iii) refund the purchase price. If a defect arises and a valid claim is received after the statutory warranty period has expired, but within the extended warranty period, OSO will supply a product that is identical or similar in function. OSO will in such cases not cover any other associated costs. In addition, for every year after the statutory warranty period, the claimant must contribute 4 % of the list price of the cylinder in question to OSO. Any exchanged Product or component will become the legal property of OSO. Any valid claim or service does not extend the original warranty. The replacement Product or part does not carry a new warranty.

### 3. Conditions

The Product is manufactured to suit most public water supplies. However, there are certain water chemistries (outlined below) that can have a detrimental effect on the Product and its life expectancy. If there are uncertainties regarding water quality, the local water supply authority can supply the necessary data.

The warranty applies only if the conditions set out below are met in full:

- The Product has been installed by a professional installer, in accordance with the instructions in the installation manual and all relevant Codes of Practice and Regulations in force at the time of installation.
- The Product has not been modified in any way, tampered with or subjected to misuse and no factory fitted parts have been removed for unauthorized repair or replacement.
- The product has been connected to the public power grid and it has not been connected to an external power supply control unit not approved by OSO.
- The Product has only been connected to a domestic mains water supply in compliance with the European Drinking Water Directive EN 98/83 EC, or latest version. The water should not be aggressive, i.e. the water chemistry shall comply with the following:

- Chloride	< 250 mg / L
- Electric Conductivity (EC) @25°C	< 750 uS / cm
- Saturation Index (LSI) @80°C	> -1,0 / < 0,8
- pH level	> 6,0 / < 9,5

- The immersion heater has not been exposed to hardness levels exceeding 5°dH (180 ppm CaCO<sub>3</sub>). A water softener is recommended in such cases.
- Any disinfection has been carried out without affecting the Product in any way whatsoever. The Product shall be isolated from any system chlorination.
- The Product has been in regular use from the date of installation. If the Product is not intended to be used for 60 days or more, it must be drained.
- The immersion heater element must be removed for inspection on service after 5 years. The threads must be checked for corrosion. If signs of corrosion are evident, the element must be replaced. Subsequently the element must be removed and examined every 3 years. Failure to do so in areas of aggressive water may result in the element separating from the cylinder with consequential escape of water.
- Service and/or repair shall be done according to the installation manual and all relevant codes of practice. Any replacement parts used shall be original OSO spare parts.
- The Service record / Benchmark logbook has been completed and updated after each annual service. Invoices should be kept as proof of service.
- The Commissioning Checklist / Benchmark certificate has been completed at the time of installation.
- Any third-party costs associated with any claim has been authorized in advance by OSO in writing.
- The purchase invoice and/or installation invoice, a water sample as well as the defective product is made available to OSO upon request.

Failure to follow these instructions and conditions may result in product failure, and water escaping from the Product.

### 4. Limitations

The warranty does not cover:

- Any fault or costs arising from incorrect installation, incorrect application, lack of regular maintenance in accordance with the installation manual, neglect, accidental or malicious damage, misuse, any alteration, tampering or repair carried out by a non-professional, any fault arising from the tampering with or removal of any factory fitted safety components or measures.
- Any consequential damage or any indirect loss caused by any failure or malfunction of the Product whatsoever.
- Any pipework or any equipment connected to the Product.
- The effects of frost, lightning, voltage variation, lack of water, connecting to a non approved external power supply control unit, dry boiling, excess pressure or chlorination procedures.
- The effects of stagnant (de-aerated) water if the Product has been left unused for more than 60 days consecutively.
- Damage caused during transportation. Buyer shall give the carrier notice of such damage.
- Costs arising if the Product is not immediately accessible for servicing.

These warranties do not affect the Buyer's statutory rights.

## 7.1 Customer service

In case of problems that cannot be resolved with the aid of the troubleshooting guide in this installation manual, contact either:

- A) The installer who supplied the product.
- B) OSO Hotwater AS: Tel.: +47 32 25 00 00  
oso@oso.no / www.oso.no

## 8. REMOVING THE PRODUCT

### 8.1 Removal

- A) Disconnect the power supply.
- B) Shut off incoming cold water supply.
- C) Empty the product of water – see section 4.4.
- D) Disconnect all pipes.
- E) The product can now be removed.

### 8.2 Returns scheme

This product is recyclable and should be taken to the environmental recycling centre. If the product is to be replaced with a new one, the installer can take the old cylinder away for recycling.

# OSO

HOTWATER

**OSO Hotwater AS**

Industriveien 1  
3300 Hokksund - Norway  
Tel: + 47 32 25 00 00  
oso@oso.no  
www.osohotwater.com